



Public Information Handout

Sewer Lateral Maintenance Procedure

Sewer Service Request Procedures

When sewer backups are experienced, the owner/resident may contact the Public Work Department at 757-5686 between the hours of 8am and 5:00pm or after hours at 747-5400. This will allow the city to correct the problem if it is in the sections of the pipe system maintained by the City (see attached figures) at no cost to owner/resident. City personnel will respond to all sanitary sewer calls from individual property owners/residents regardless of whether the resident initially calls the plumbing contractor or the City.

City personnel will check the sewer main in the street or easement. If the inspection reveals a problem in the sewer main, city personnel will correct the problem and inform the owner/resident of the findings.

If the sewer main is operating properly and the property has a service lateral cleanout, city personnel will determine if the service lateral is operating properly. If the service lateral is blocked, city personnel will correct the problem and inform owner/resident of the findings. Note See Figure 1.

If the service lateral is operating properly, or the service lateral cleanout is blocked by landscaping/concrete or does not exist, City personnel will inform the owner/resident that a plumber is required to clear the blockage or expose the service lateral cleanout for City personnel to further inspect the lateral.

The city does not have service lateral cleanouts or service laterals in backyard easements. Note: see figure 2.

FIGURE 1: FRONT YARD SEWER LATERAL

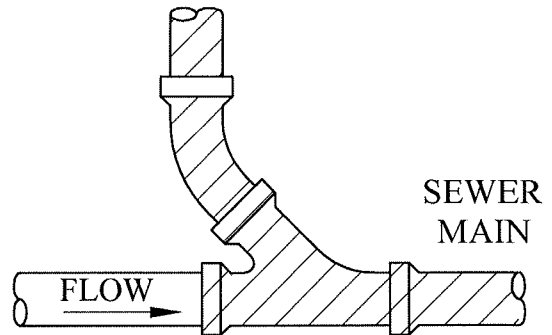
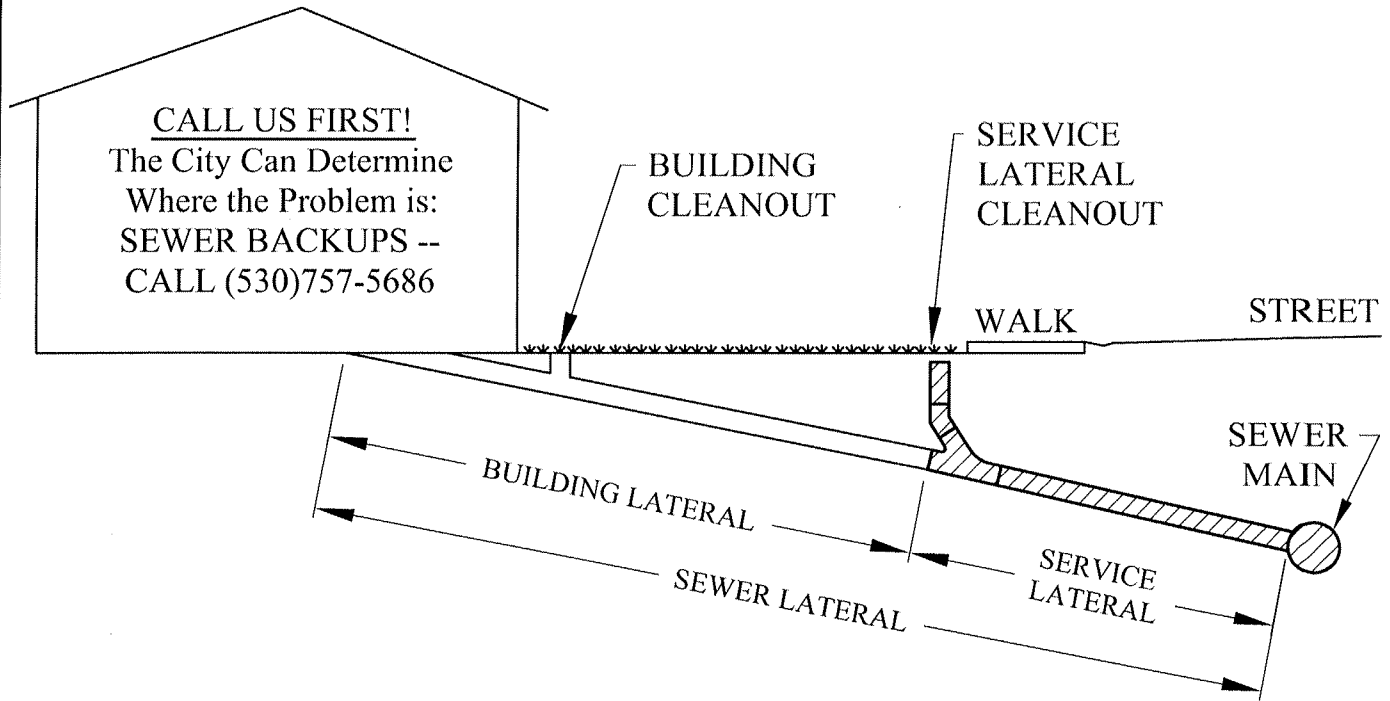

THE CITY OF DAVIS SANITARY SEWER IS INDICATED BY THE CROSS-HATCHED AREA.

**SEWER LATERAL
RIGHT-OF-WAY SERVICE**



**CITY OF DAVIS
PUBLIC WORKS DEPARTMENT
APRIL 2007**

FIGURE 2: BACK YARD SEWER LATERAL

PROPERTY OWNER'S
BACKYARD

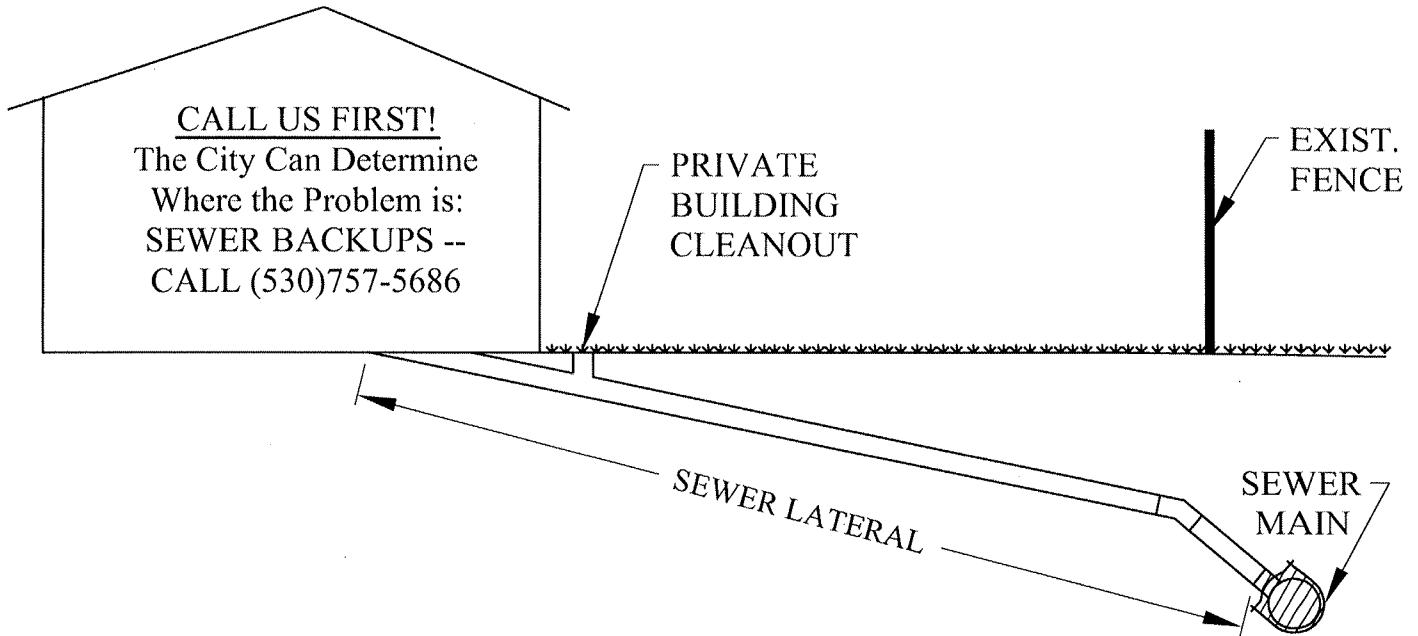

THE CITY OF DAVIS SANITARY SEWER IS INDICATED BY THE CROSS-HATCHED AREA ON THE SKETCH.

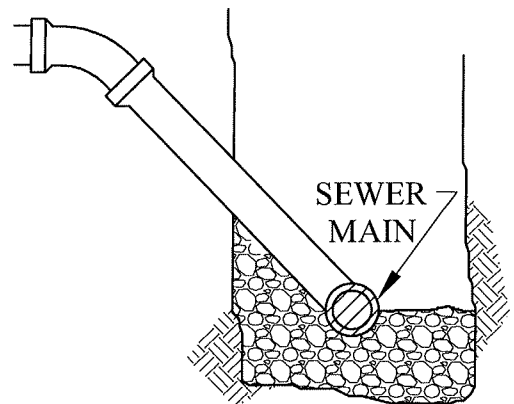

NOTE:
THE CITY DOES NOT HAVE A SERVICE CLEANOUT NOR SERVICE LATERAL IN A BACKYARD SEWER MAIN ALIGNMENT.

**SEWER LATERAL
EASEMENT SERVICE**



CITY OF DAVIS
PUBLIC WORKS DEPARTMENT
APRIL 2007