

VARSITY® DV215 BIKE DOCK DENSITY INFO SHEET

This graph displays the required footage for three aisle spaces with the Varsity® Bike Dock. For highest user satisfaction and free movement, 24" aisles are most commonly recommended. For more dense parking, the Varsity® may use 21" or even 18" aisles.

	Width of Aisle		
	24"	21"	18"
Perpendicular	38"	35"	32"

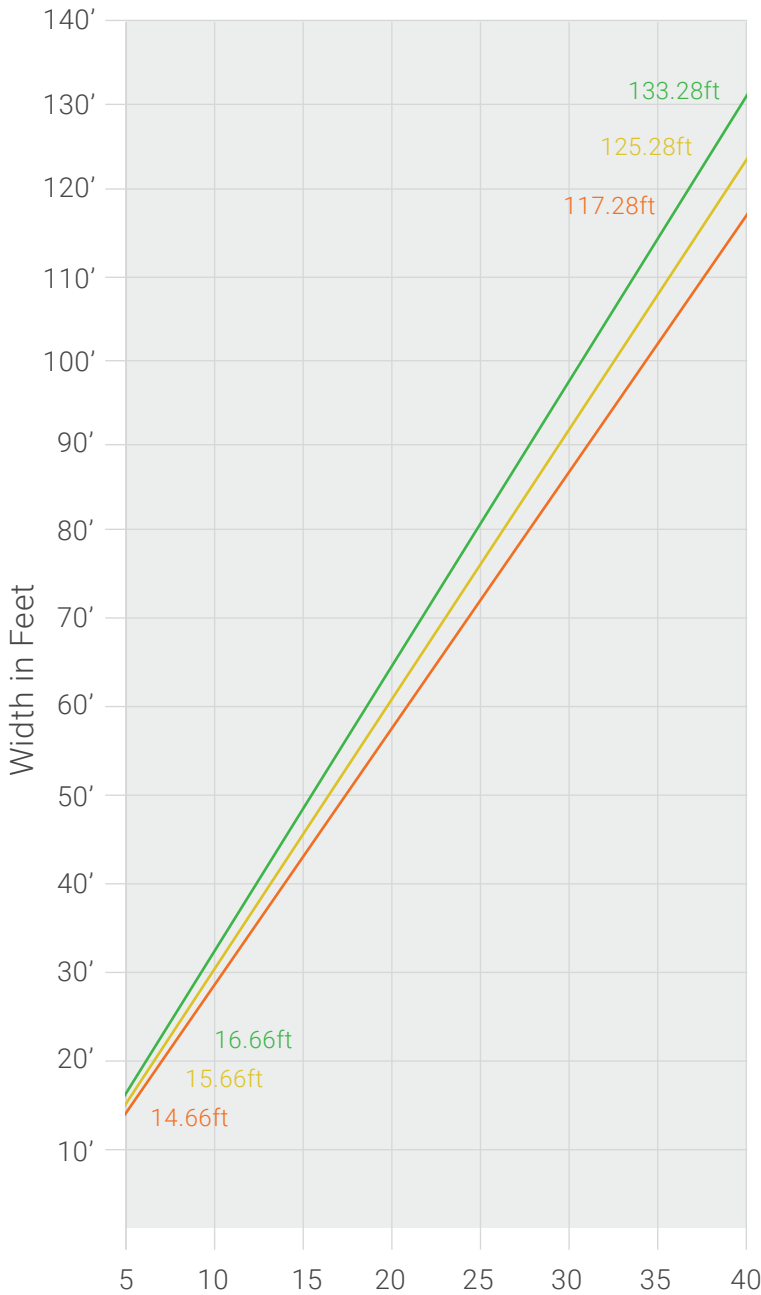

Number of Docks

To determine the number of bikes that will fit in a space, multiply the number of docks by 2.

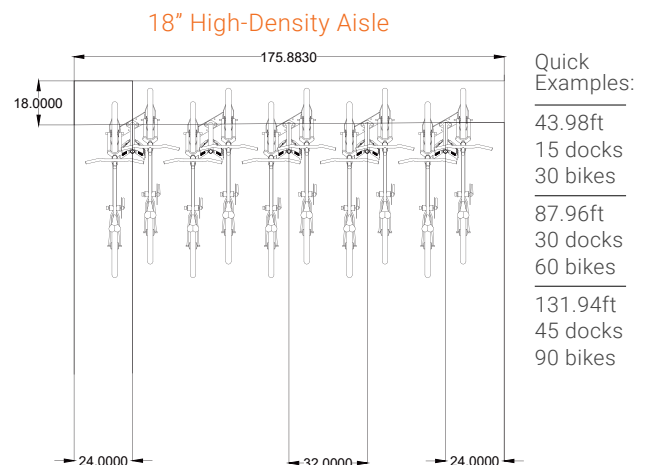
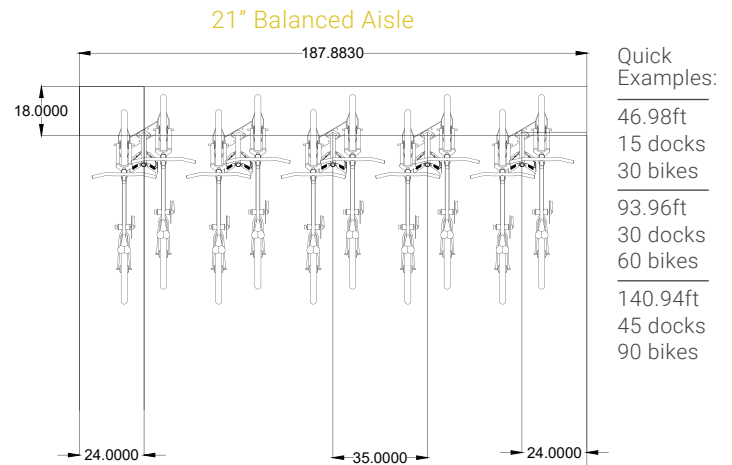
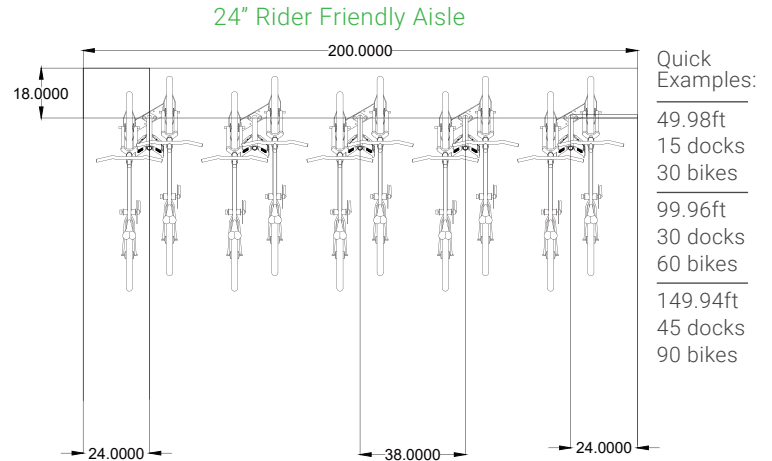

DV215 ANGLED BIKE PARKING - 18" SEPARATION - 4 BIKES SECURED

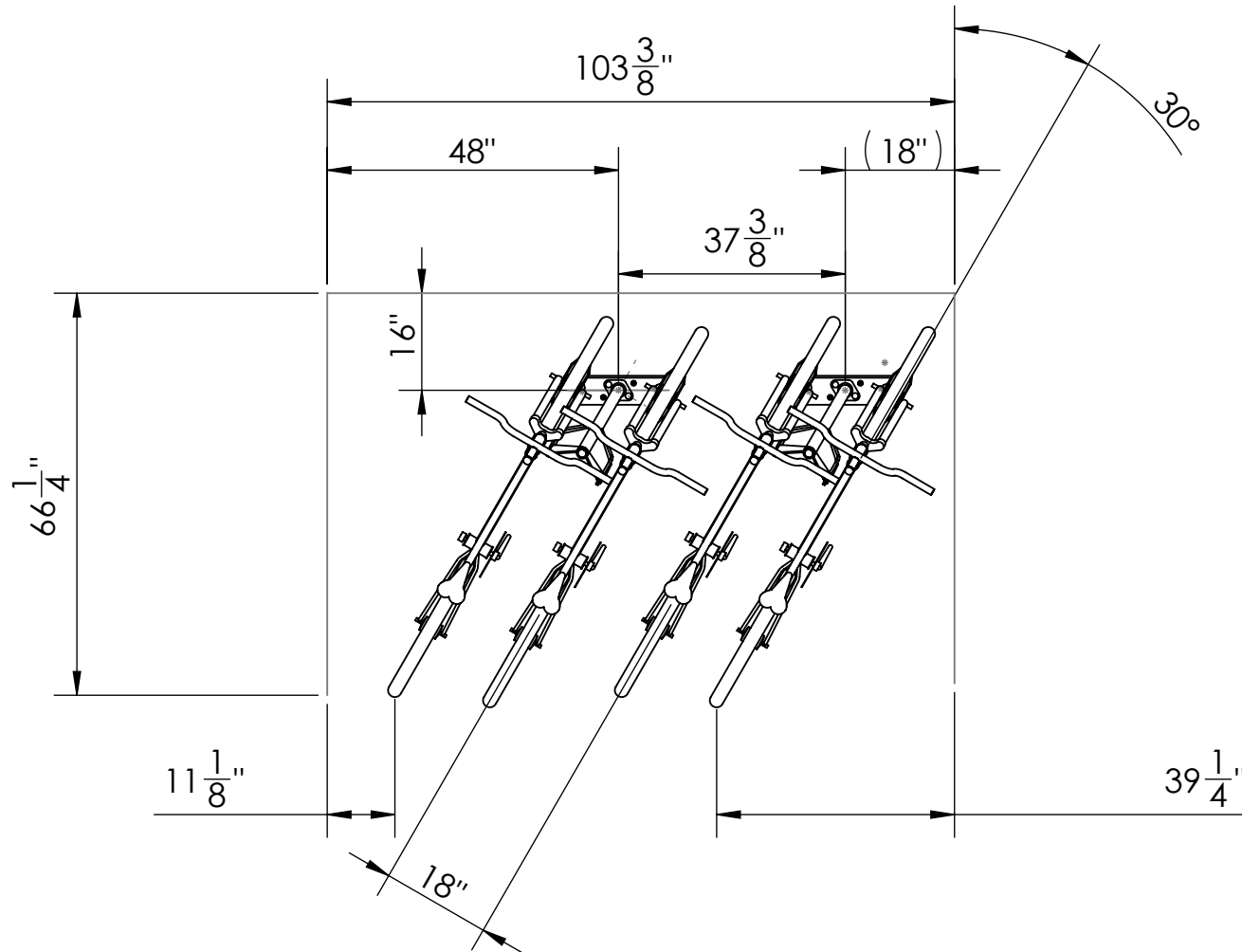

DV215 ANGLED BIKE PARKING - 18" SEPARATION - 6 BIKES SECURED

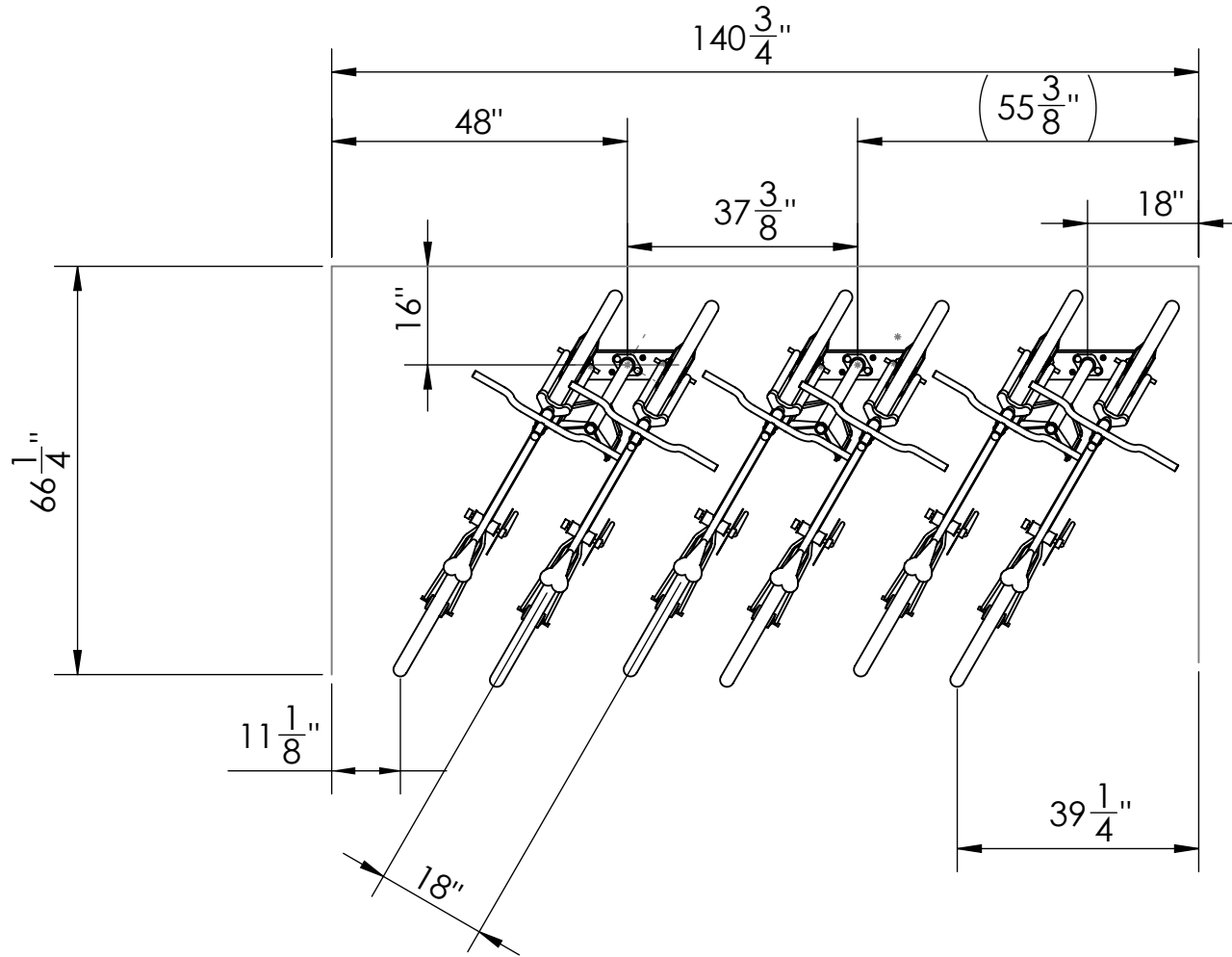

DV211 ANGLED BIKE PARKING - 18" SEPARATION - 8 BIKES SECURED

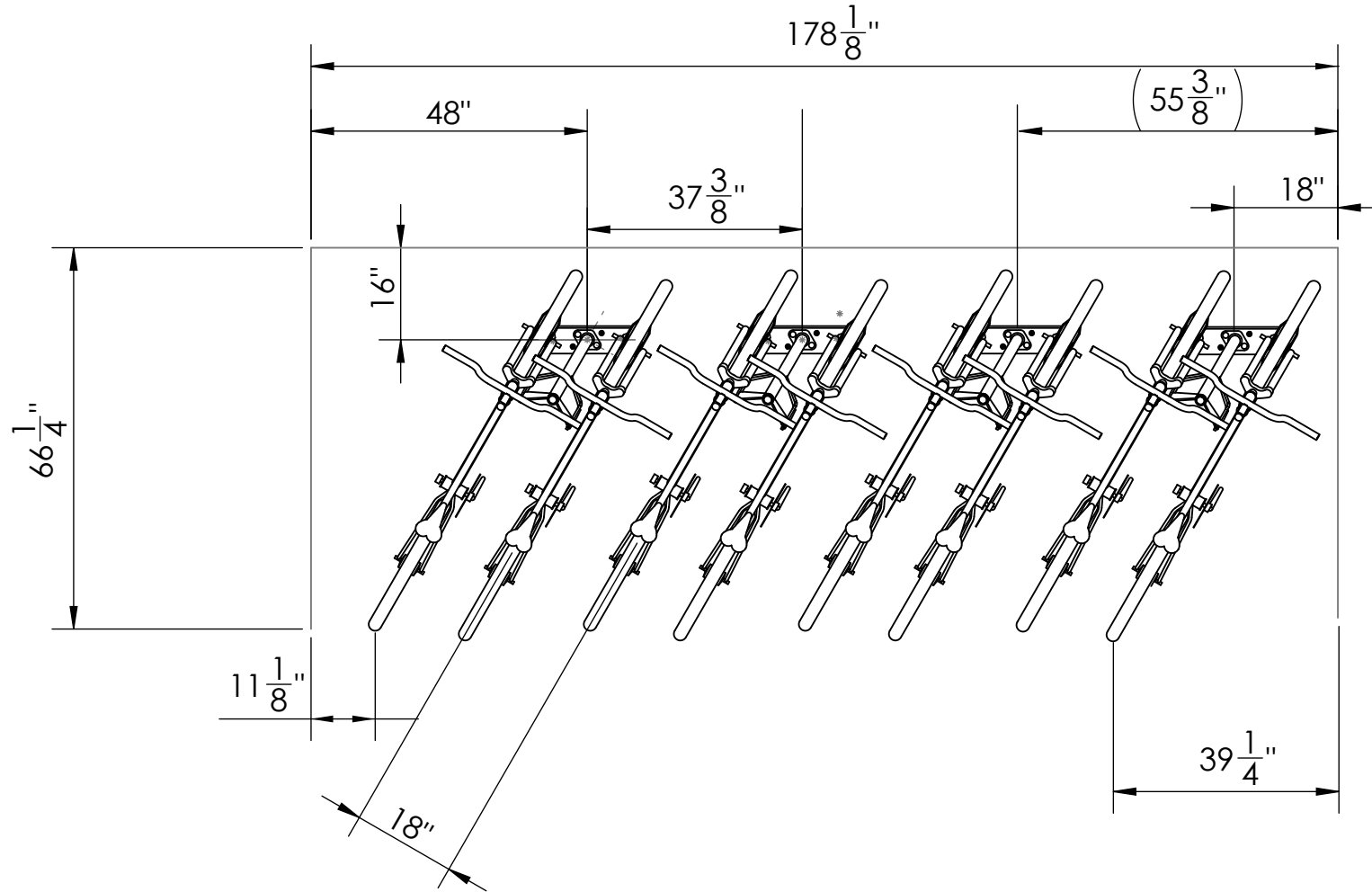

DV215 ANGLED BIKE PARKING - 18" SEPARATION - 10 BIKES SECURED

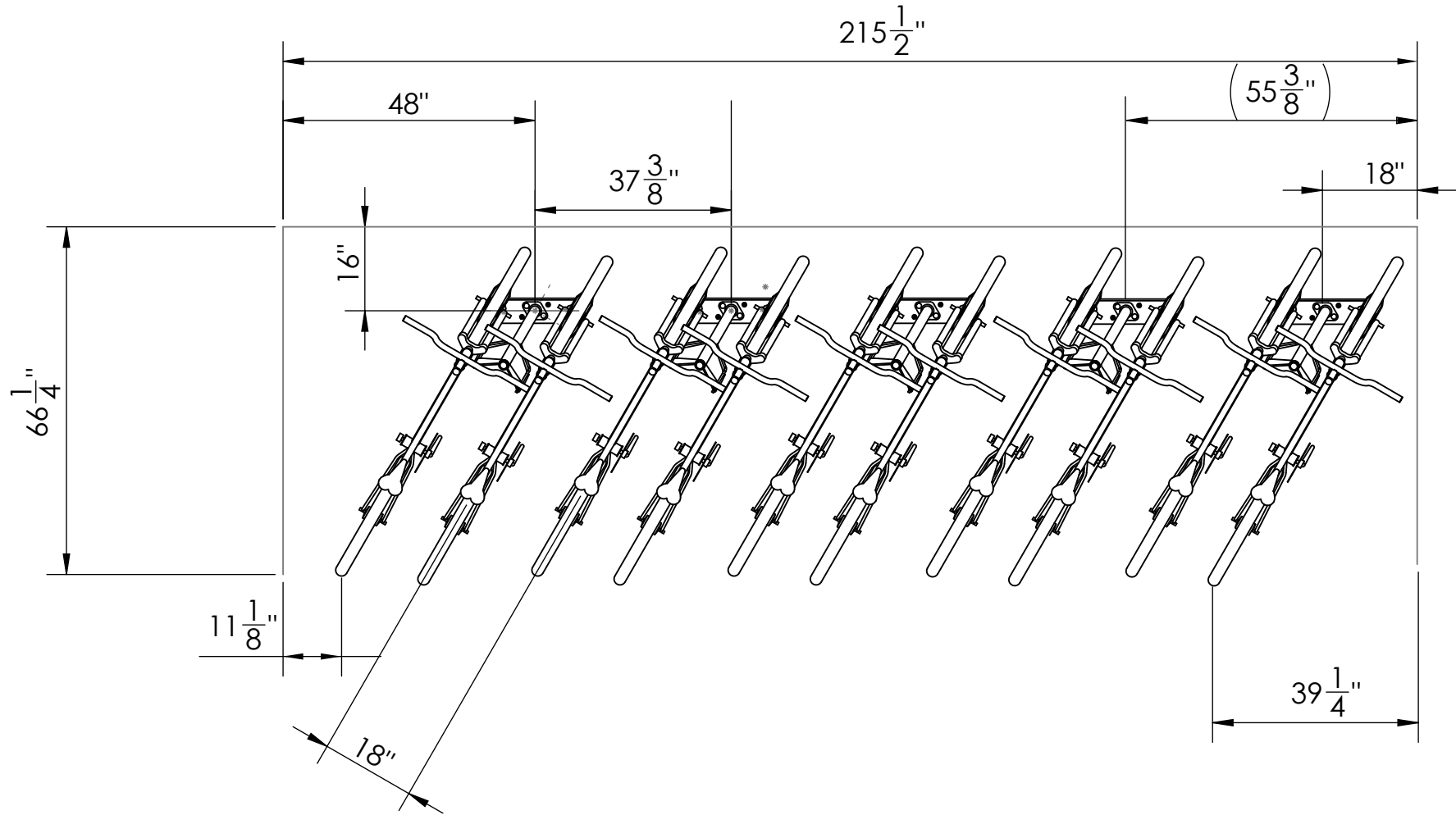

DV215 ANGLED BIKE PARKING - 24" SEPARATION - 4 BIKES SECURED

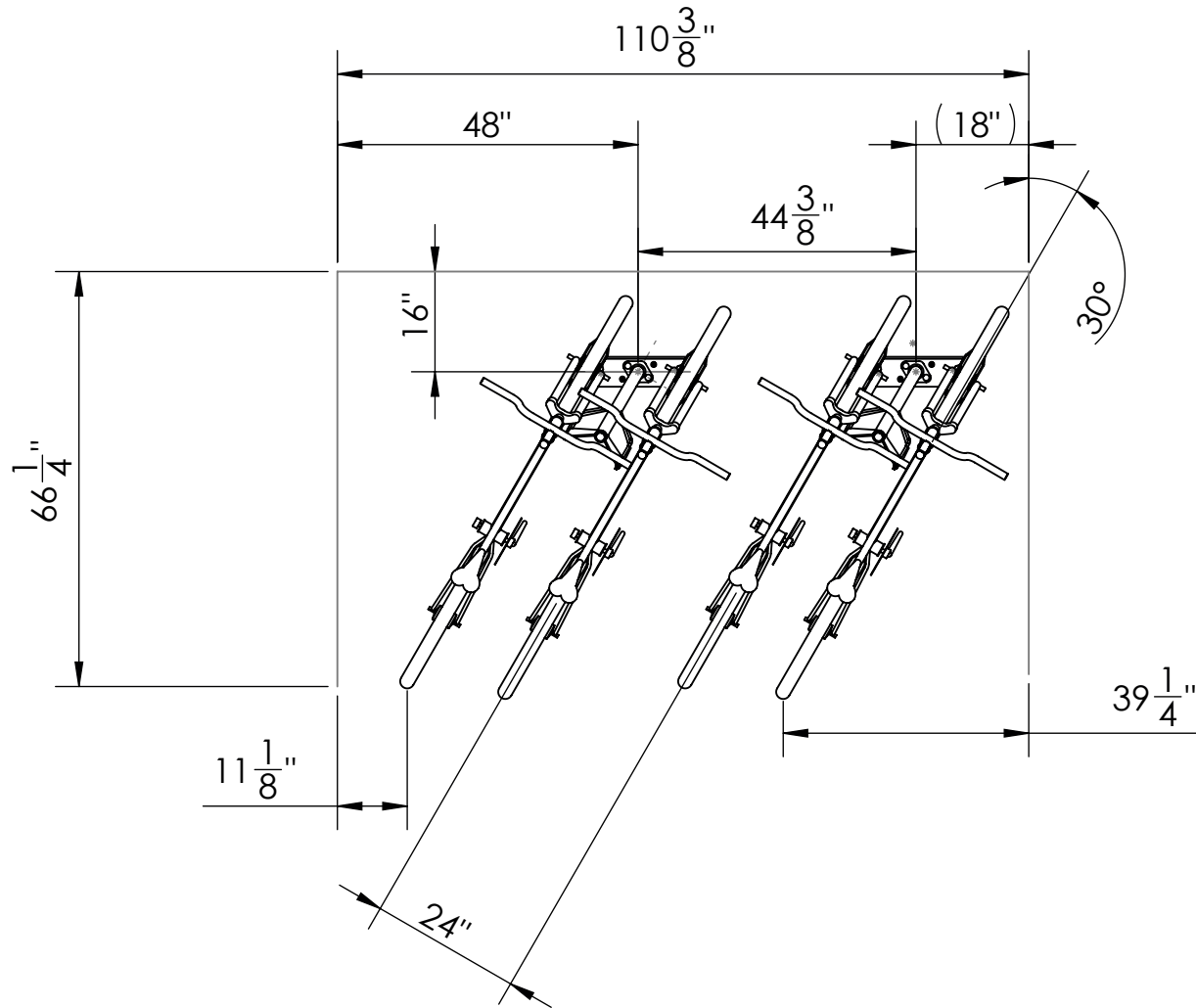

DV215 ANGLED BIKE PARKING - 24" SEPARATION - 6 BIKES SECURED

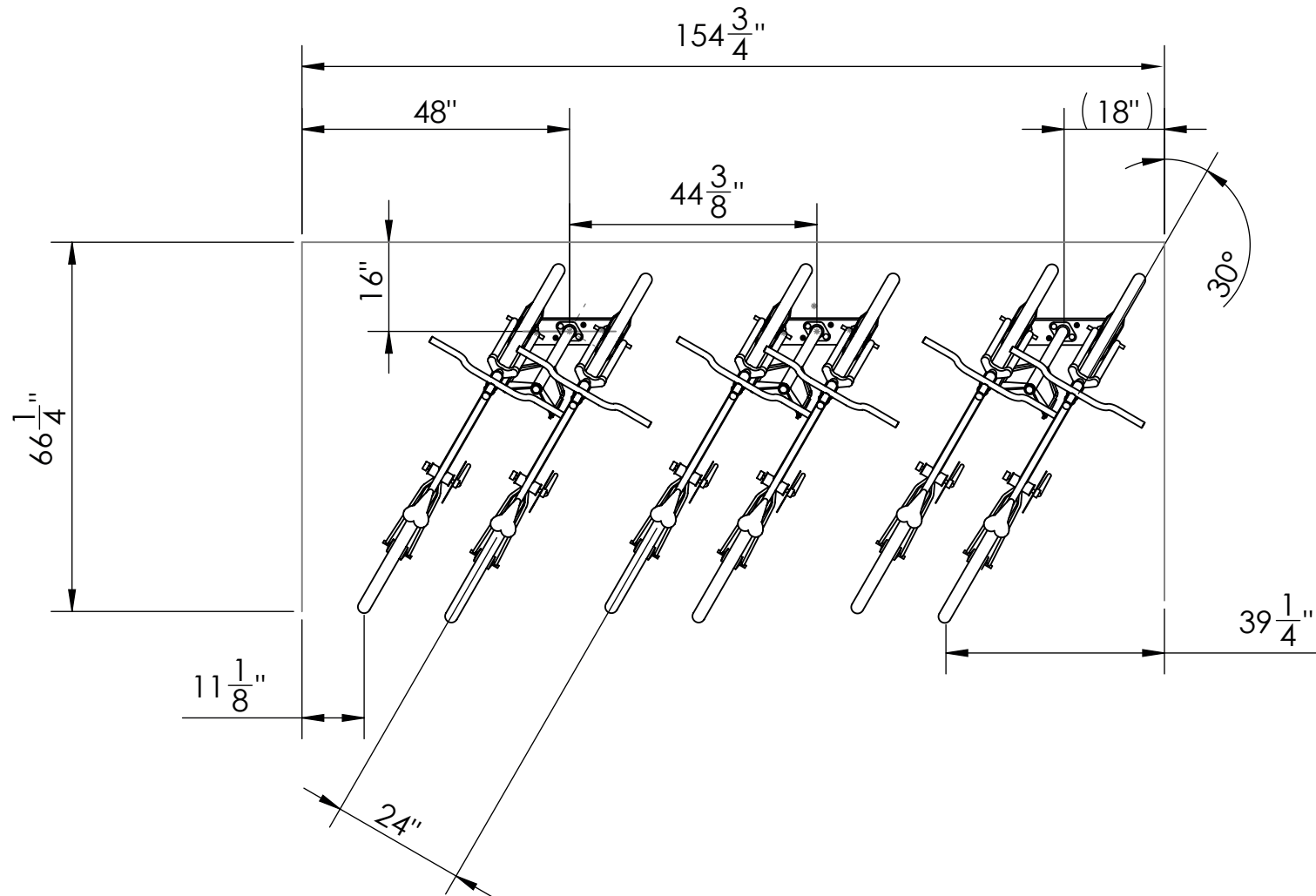

DV215 ANGLED BIKE PARKING - 24" SEPARATION - 8 BIKES SECURED

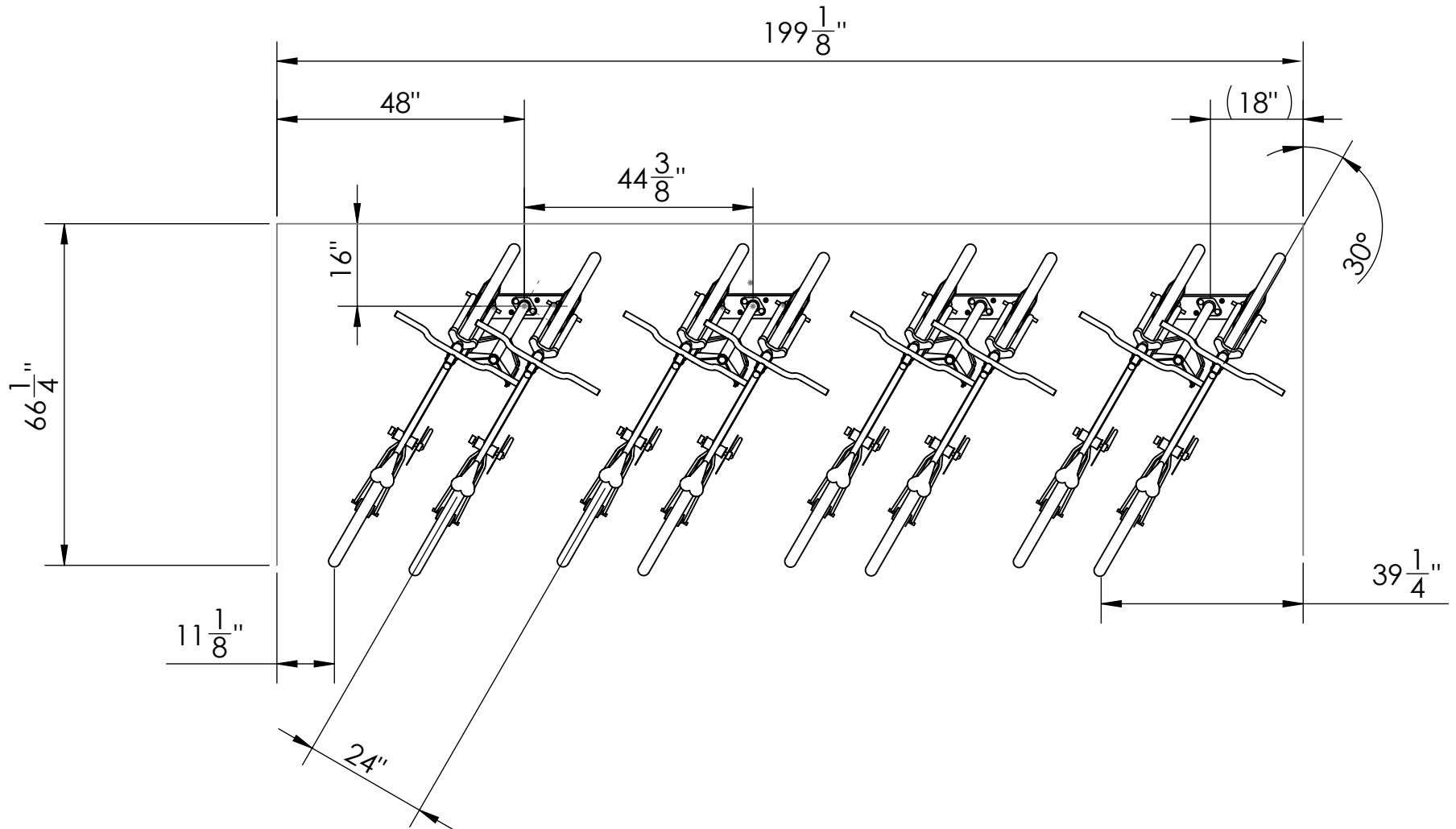

DV215 ANGLED BIKE PARKING - 24" SEPARATION - 10 BIKES SECURED

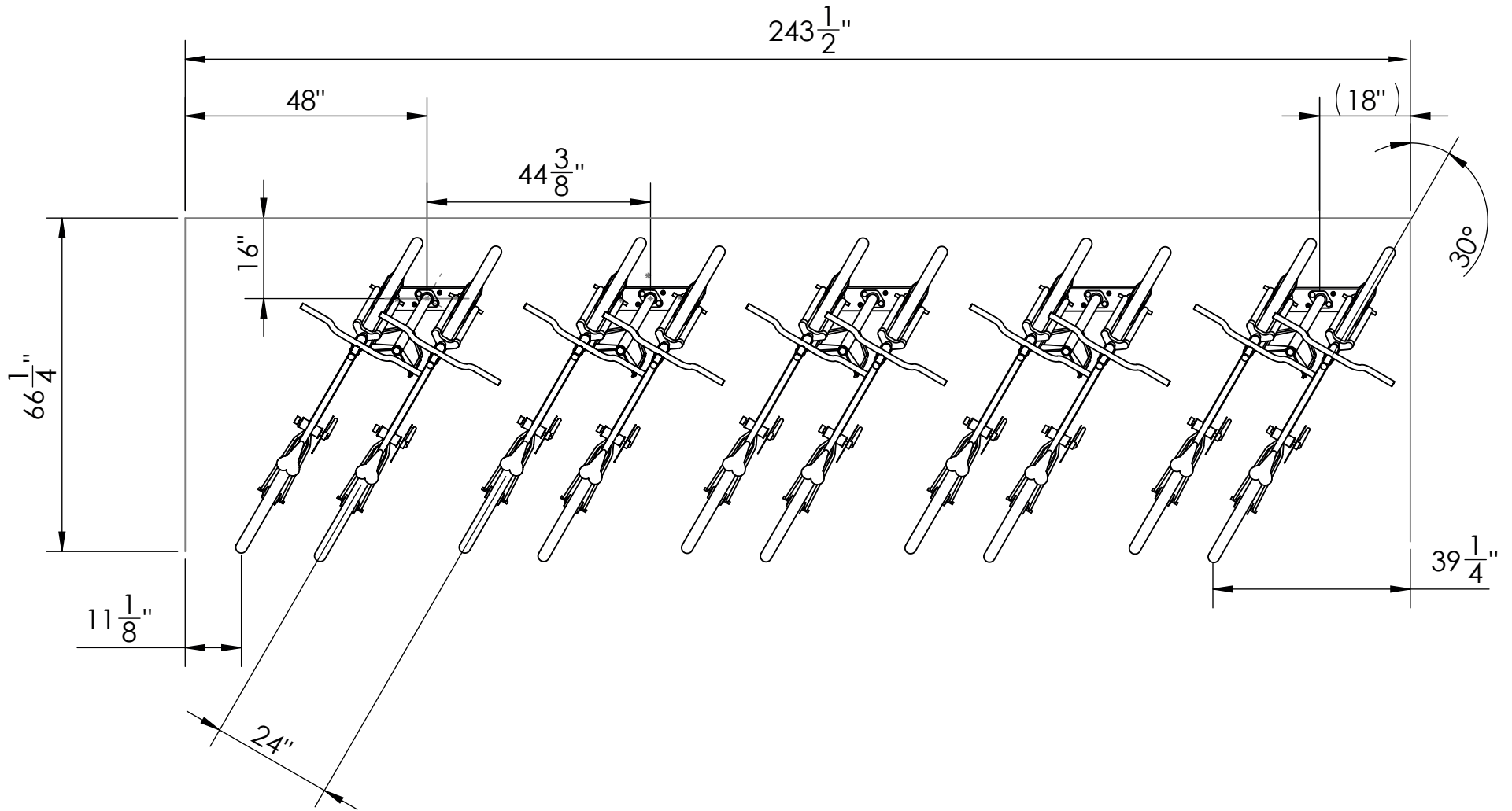

DV211 PERPENDICULAR BIKE PARKING - 18" SEPARATION - 4 BIKES SECURED- RIGHT WHEEL FORWARD

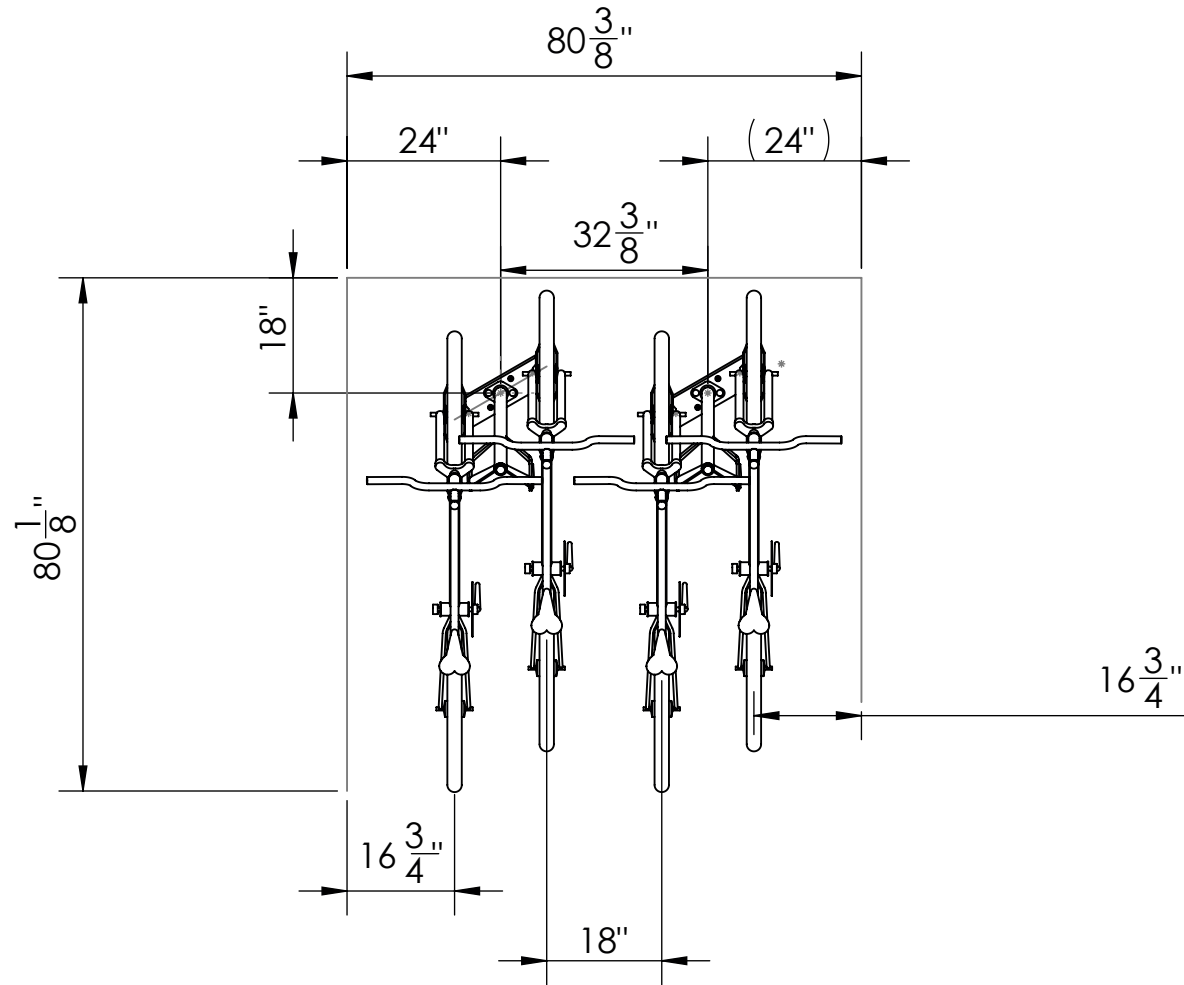

DV211 PERPENDICULAR BIKE PARKING - 18" SEPARATION - 6 BIKES SECURED- RIGHT WHEEL FORWARD

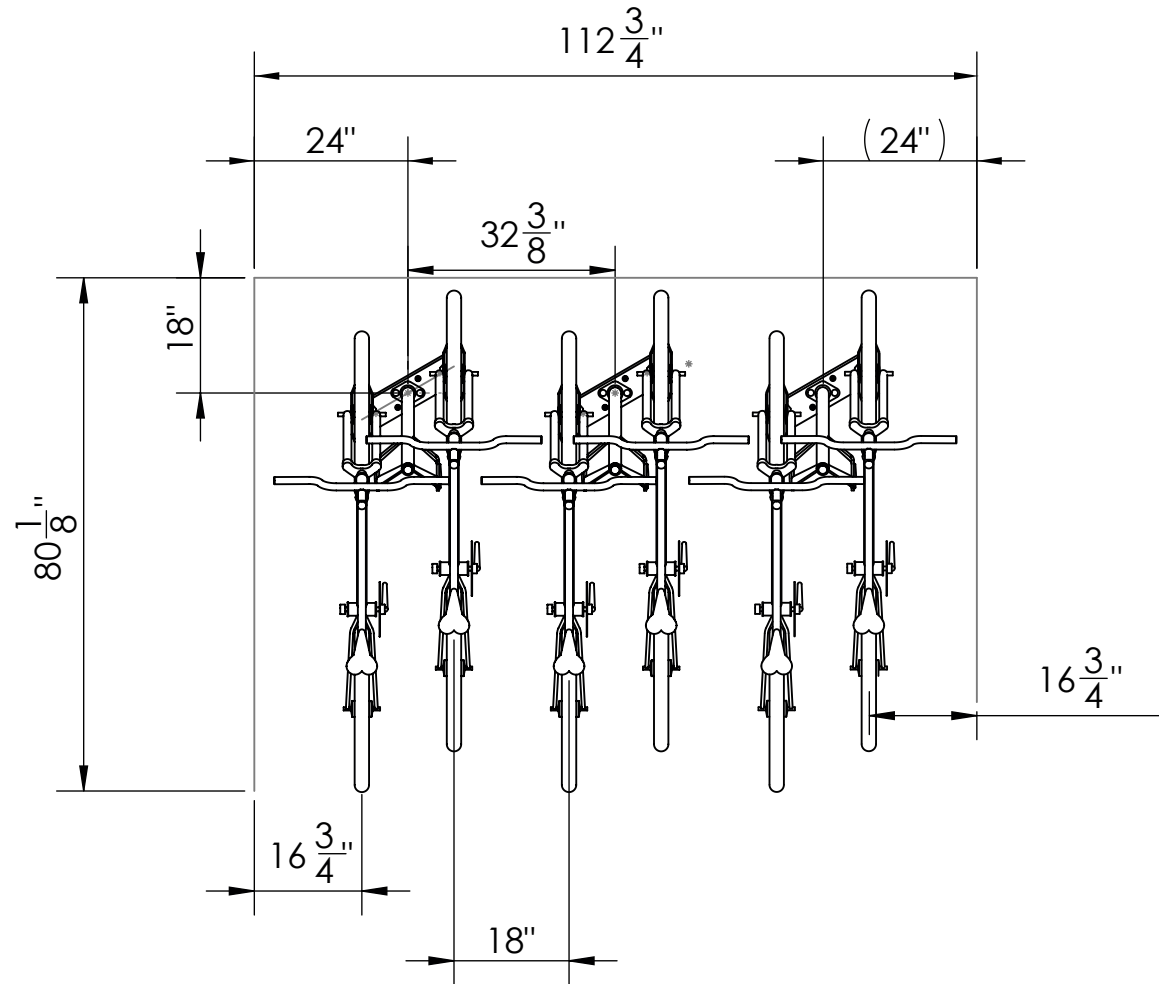

DESCRIPTION:

DV211 PERPENDICULAR BIKE PARKING - 18" SEPARATION - 8 BIKES SECURED- RIGHT WHEEL FORWARD

GROUND CONTROL
 SYSTEMS

PART FILE NUMBER:

PAB ORDER NUMBER

REV.

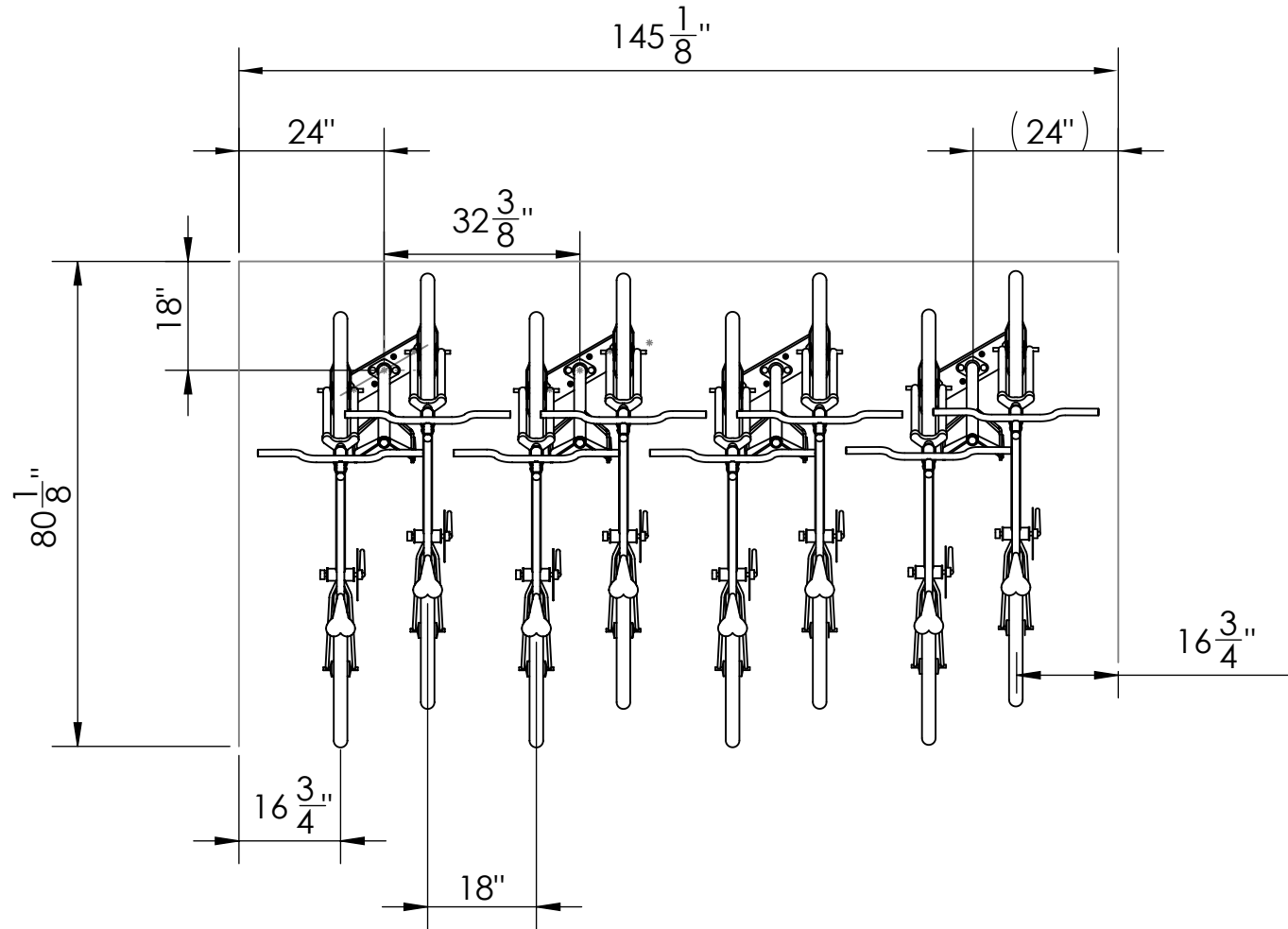

PRINT APPROVAL	NAME	DATE
DRAWN:		
ENGRINEERING:		
MANUFACTURING:		
FINAL:		

UNLESS OTHERWISE NOTED OR DIMENSIONED:
 CENTER FEATURES ABOUT ϕ
 X0. Y0. AT CENTER OF STOCK
 DIMENSIONS ARE IN INCHES
 TOLERANCES: 0.X ± 0.05 0.XX ± 0.01 0.XXX ± 0.005

PROPRIETARY AND CONFIDENTIAL STATEMENT

THE INFORMATION CONTAINED IN THIS DRAWING IS THE SOLE PROPERTY OF PARK-A-BIKE, INC.. ANY REPRODUCTION INPART OR AS A WHOLE IS STRICTLY PROHIBITED WITHOUT THE WRITTEN PERMISSION OF PARK-A-BIKE, INC.

STOCK	MATERIAL	FINISH	SIZE: A
DO NOT SCALE DRAWING	SCALE: 1:30	WEIGHT:	SHEET 3 OF 8

DESCRIPTION:

DV211 PERPENDICULAR BIKE PARKING - 18" SEPARATION - 10 BIKES SECURED- RIGHT WHEEL FORWARD



PART FILE NUMBER:

PAB ORDER NUMBER

REV.

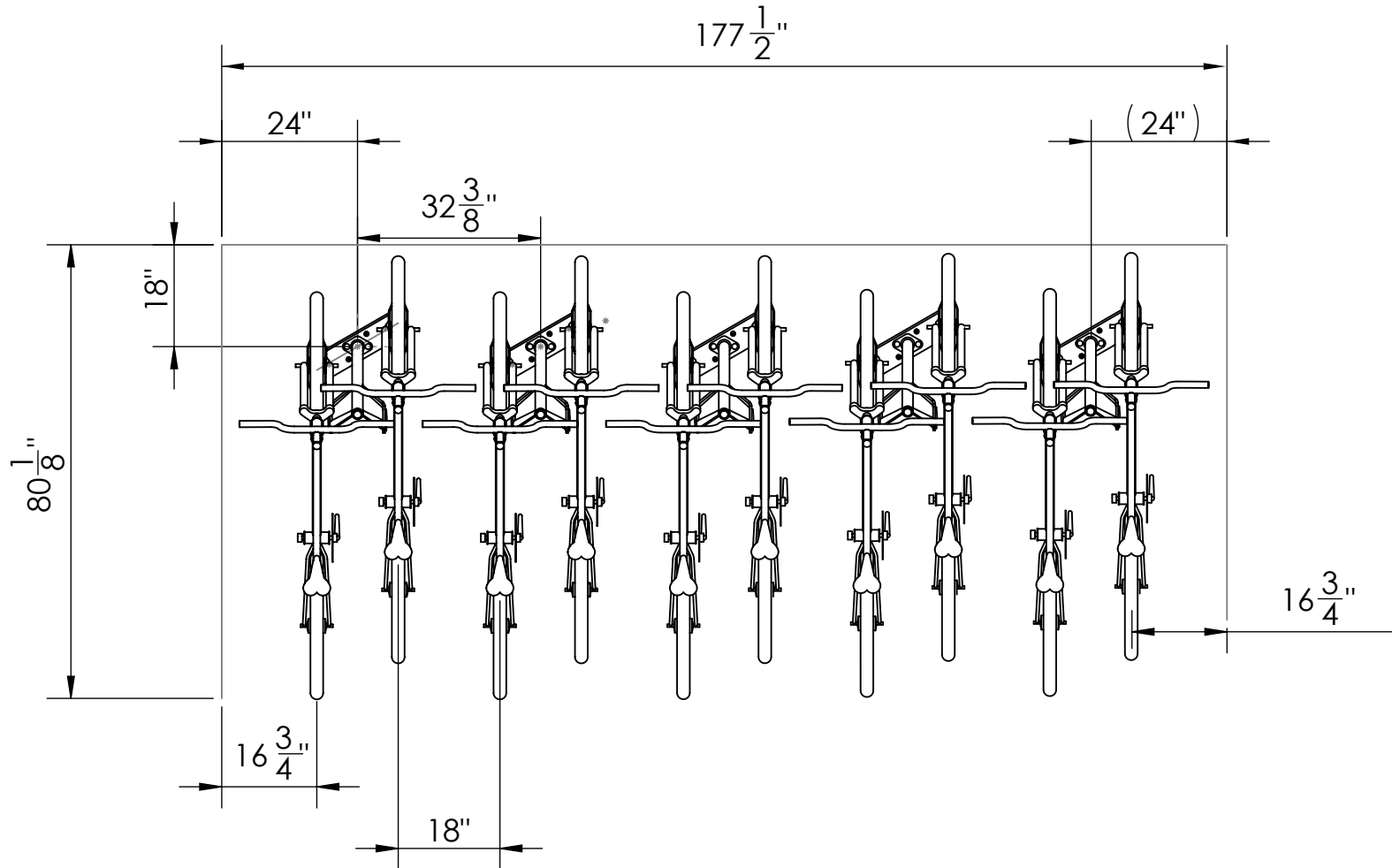

PRINT APPROVAL	NAME	DATE
DRAWN:		
ENGINEERING:		
MANUFACTURING:		
FINAL:		

UNLESS OTHERWISE NOTED OR DIMENSIONED:
 CENTER FEATURES ABOUT ϕ
 X0, Y0, AT CENTER OF STOCK
 DIMENSIONS ARE IN INCHES
 TOLERANCES: 0.X ± 0.05 0.XX ± 0.01 0.XXX ± 0.005

PROPRIETARY AND CONFIDENTIAL STATEMENT

THE INFORMATION CONTAINED IN THIS DRAWING IS THE SOLE PROPERTY OF PARK-A-BIKE, INC.. ANY REPRODUCTION INPART OR AS A WHOLE IS STRICTLY PROHIBITED WITHOUT THE WRITTEN PERMISSION OF PARK-A-BIKE, INC.

STOCK	MATERIAL	FINISH	SIZE: A
DO NOT SCALE DRAWING SCALE: 1:30		WEIGHT:	SHEET 4 OF 8

DESCRIPTION:

DV211 PERPENDICULAR BIKE PARKING - 24" SEPARATION - 4 BIKES SECURED- RIGHT WHEEL FORWARD



PART FILE NUMBER:

PAB ORDER NUMBER

REV.

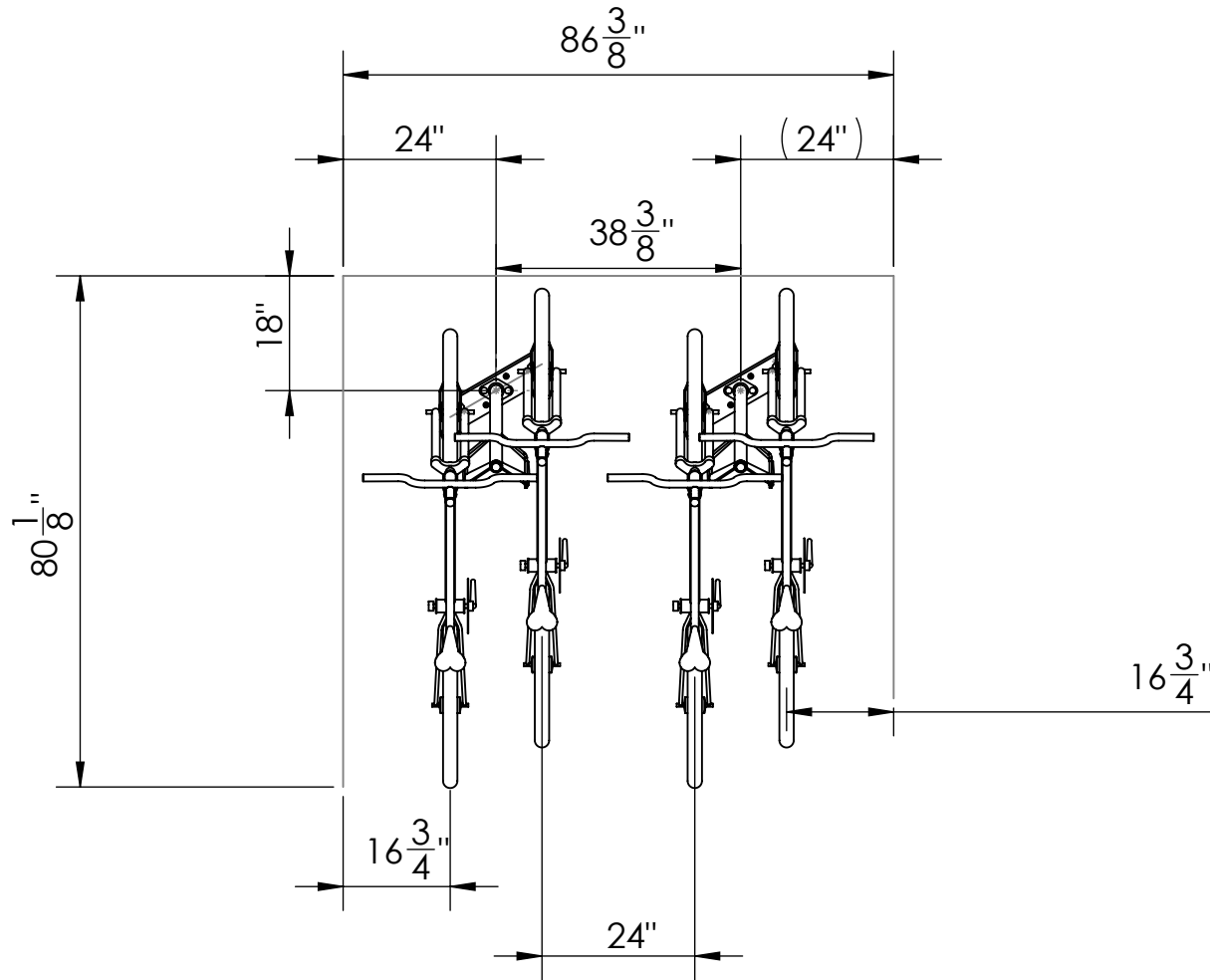

PRINT APPROVAL	NAME	DATE
DRAWN:		
ENGRINEERING:		
MANUFACTURING:		
FINAL:		

UNLESS OTHERWISE NOTED OR DIMENSIONED:
 CENTER FEATURES ABOUT ϕ
 X0. Y0. AT CENTER OF STOCK
 DIMENSIONS ARE IN INCHES
 TOLERANCES: 0.X ± 0.05 0.XX ± 0.01 0.XXX ± 0.005

PROPRIETARY AND CONFIDENTIAL STATEMENT

THE INFORMATION CONTAINED IN THIS DRAWING IS THE SOLE PROPERTY OF PARK-A-BIKE, INC.. ANY REPRODUCTION INPART OR AS A WHOLE IS STRICTLY PROHIBITED WITHOUT THE WRITTEN PERMISSION OF PARK-A-BIKE, INC.

STOCK	MATERIAL	FINISH	SIZE: A
DO NOT SCALE DRAWING SCALE: 1:30		WEIGHT:	SHEET 5 OF 8

DESCRIPTION:

DV211 PERPENDICULAR BIKE PARKING - 24" SEPARATION - 6 BIKES SECURED- RIGHT WHEEL FORWARD



PART FILE NUMBER:

PAB ORDER NUMBER

REV.

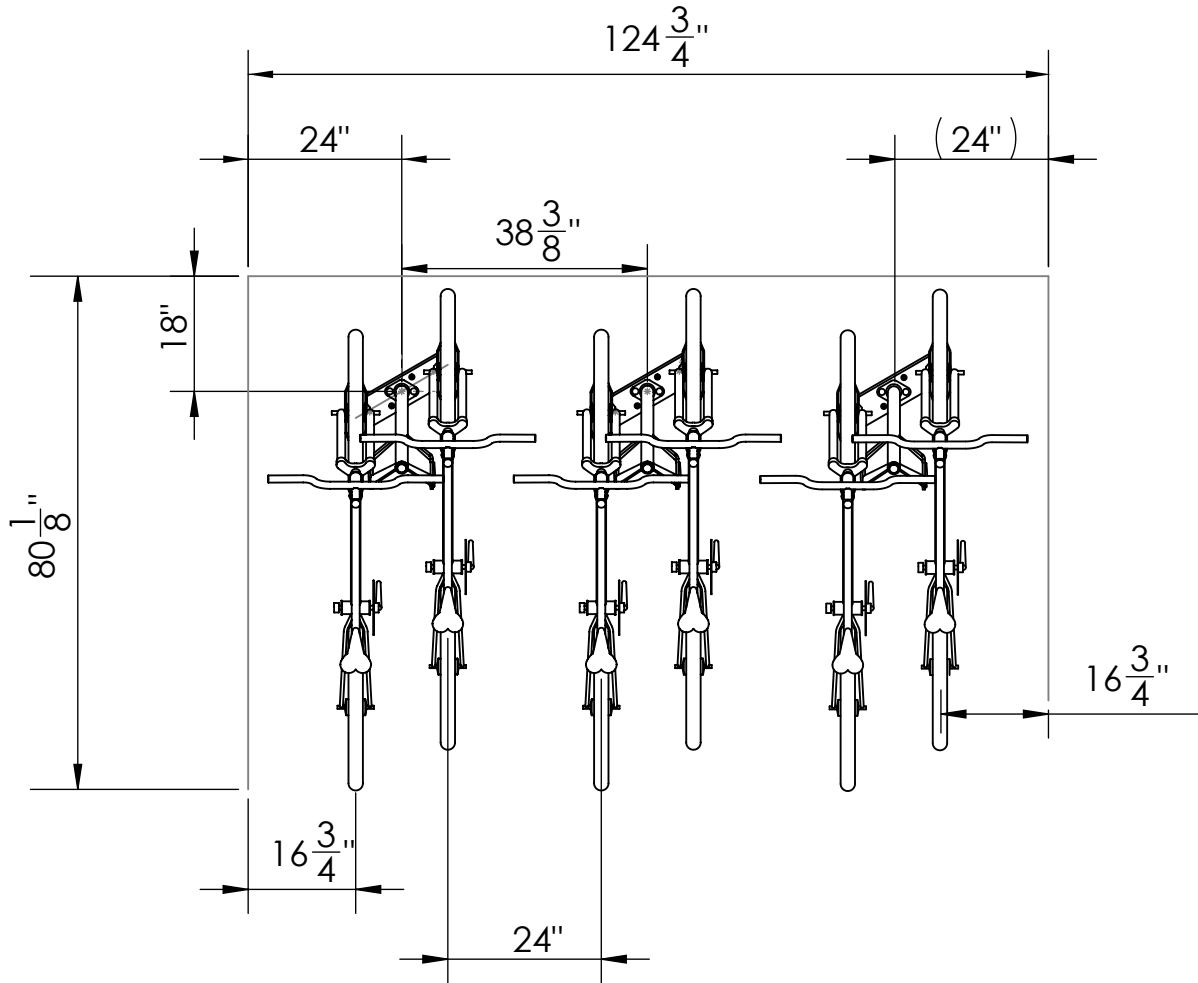

PRINT APPROVAL	NAME	DATE
DRAWN:		
ENGINEERING:		
MANUFACTURING:		
FINAL:		

UNLESS OTHERWISE NOTED OR DIMENSIONED:
 CENTER FEATURES ABOUT ϕ
 X0, Y0, AT CENTER OF STOCK
 DIMENSIONS ARE IN INCHES
 TOLERANCES: 0.X ± 0.05 0.XX ± 0.01 0.XXX ± 0.005

PROPRIETARY AND CONFIDENTIAL STATEMENT
 THE INFORMATION CONTAINED IN THIS DRAWING IS THE SOLE PROPERTY OF
 PARK-A-BIKE, INC.. ANY REPRODUCTION INPART OR AS A WHOLE IS STRICTLY
 PROHIBITED WITHOUT THE WRITTEN PERMISSION OF PARK-A-BIKE, INC.

STOCK	MATERIAL	FINISH	SIZE: A
DO NOT SCALE DRAWING SCALE: 1:30		WEIGHT:	SHEET 6 OF 8

DESCRIPTION:

DV211 PERPENDICULAR BIKE PARKING - 24" SEPARATION - 8 BIKES SECURED- RIGHT WHEEL FORWARD



PART FILE NUMBER:

PAB ORDER NUMBER

REV.

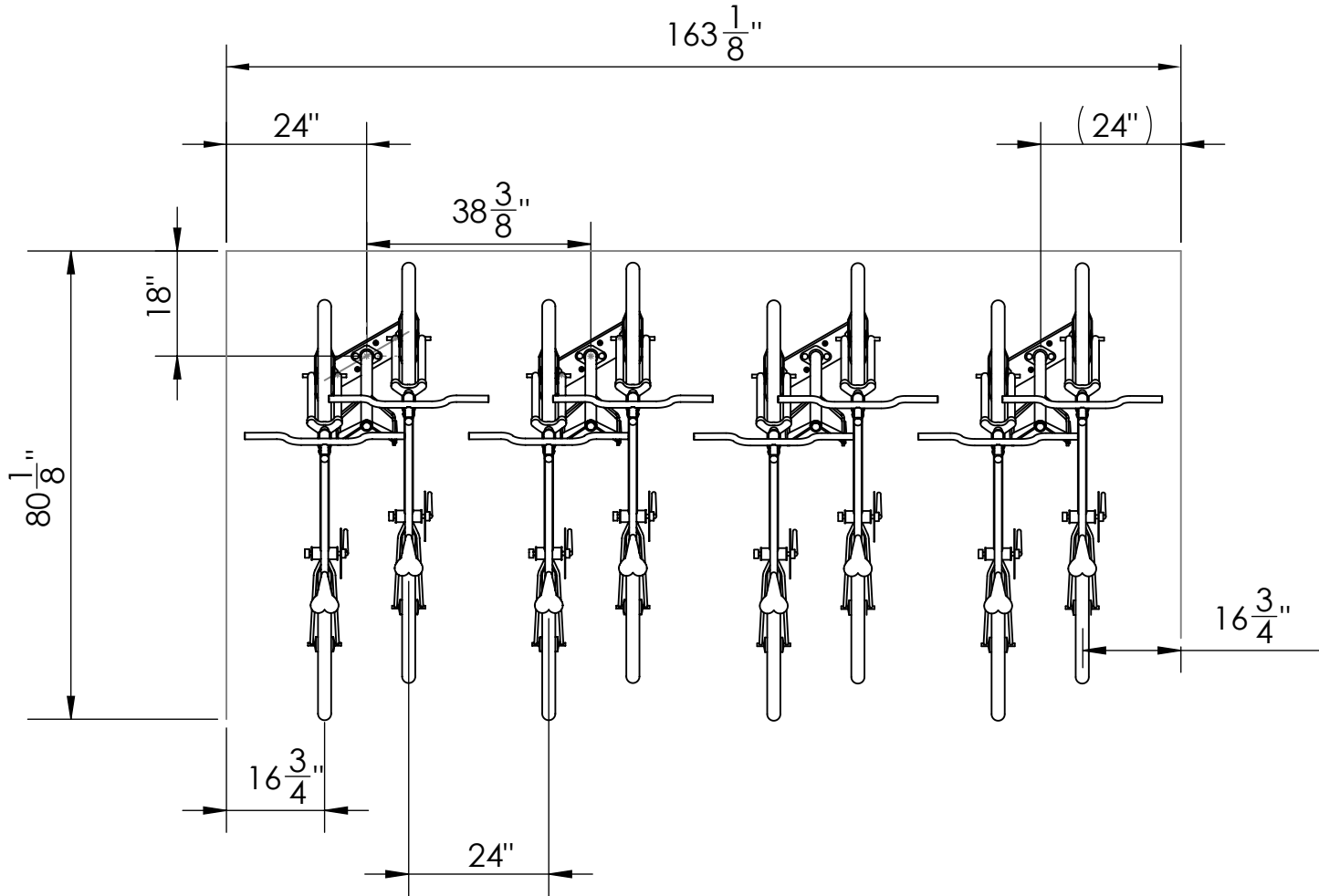

PRINT APPROVAL	NAME	DATE
DRAWN:		
ENGRINEERING:		
MANUFACTURING:		
FINAL:		

UNLESS OTHERWISE NOTED OR DIMENSIONED:
 CENTER FEATURES ABOUT ϕ
 X0. Y0. AT CENTER OF STOCK
 DIMENSIONS ARE IN INCHES
 TOLERANCES: 0.X ± 0.05 0.XX ± 0.01 0.XXX ± 0.005

PROPRIETARY AND CONFIDENTIAL STATEMENT

THE INFORMATION CONTAINED IN THIS DRAWING IS THE SOLE PROPERTY OF PARK-A-BIKE, INC.. ANY REPRODUCTION INPART OR AS A WHOLE IS STRICTLY PROHIBITED WITHOUT THE WRITTEN PERMISSION OF PARK-A-BIKE, INC.

STOCK	MATERIAL	FINISH	SIZE: A
DO NOT SCALE DRAWING SCALE: 1:30		WEIGHT:	SHEET 7 OF 8

DESCRIPTION:

DV211 PERPENDICULAR BIKE PARKING - 24" SEPARATION - 10 BIKES SECURED- RIGHT WHEEL FORWARD



PART FILE NUMBER:

PAB ORDER NUMBER

REV.

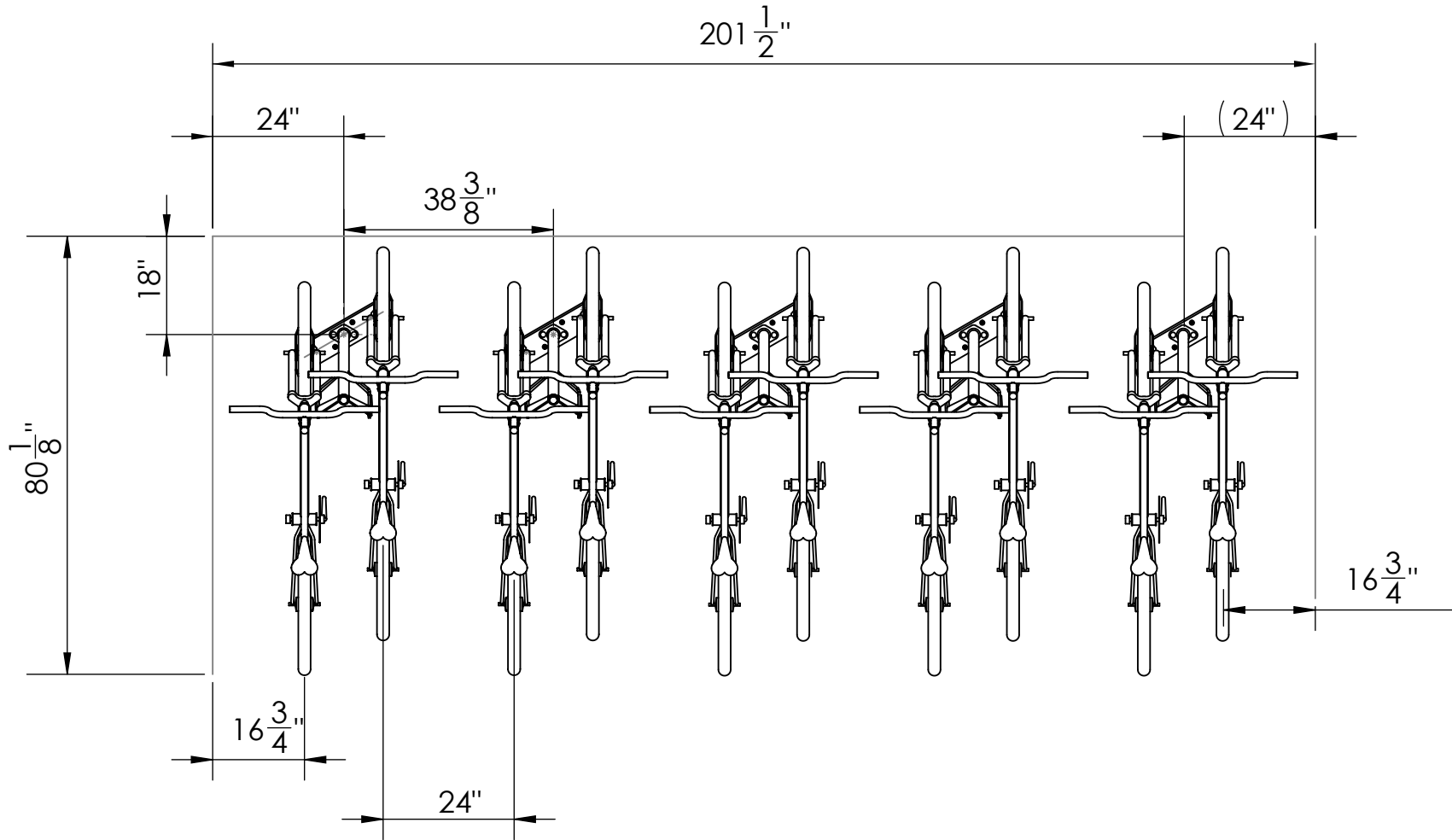

PRINT APPROVAL	NAME	DATE
DRAWN:		
ENGRINEERING:		
MANUFACTURING:		
FINAL:		

UNLESS OTHERWISE NOTED OR DIMENSIONED:
 CENTER FEATURES ABOUT ϕ
 X0. Y0. AT CENTER OF STOCK
 DIMENSIONS ARE IN INCHES
 TOLERANCES: 0.X ± 0.05 0.XX ± 0.01 0.XXX ± 0.005

PROPRIETARY AND CONFIDENTIAL STATEMENT

THE INFORMATION CONTAINED IN THIS DRAWING IS THE SOLE PROPERTY OF PARK-A-BIKE, INC.. ANY REPRODUCTION INPART OR AS A WHOLE IS STRICTLY PROHIBITED WITHOUT THE WRITTEN PERMISSION OF PARK-A-BIKE, INC.

STOCK	MATERIAL	FINISH	SIZE: A
DO NOT SCALE DRAWING	SCALE: 1:30	WEIGHT:	SHEET 8 OF 8