

G Street Activation Project, Design and Construction Meeting

Ryan Chapman

**Assistant Director Of Public Works Engineering and
Transportation/Traffic Engineer**



Meeting Engagement

1. Presentation

2. Enter questions into the Q&A function.

Purpose

- **Discuss G Street design, construction and schedule.**
- **Future meeting to discuss the use of the space.**



Layout

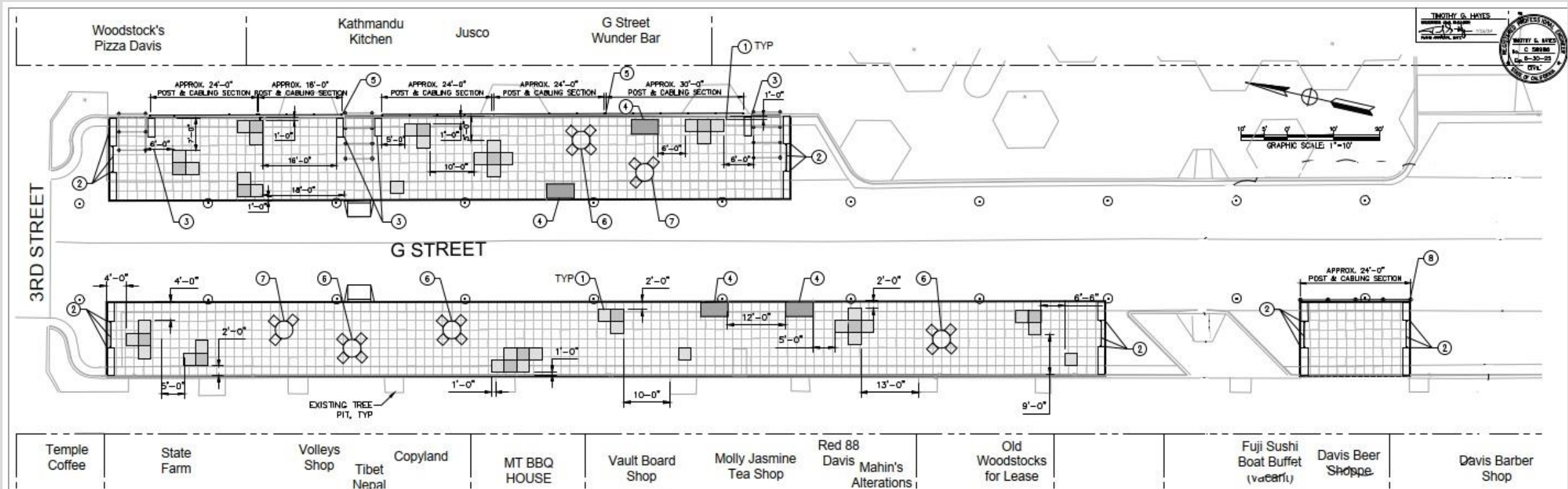

Layout

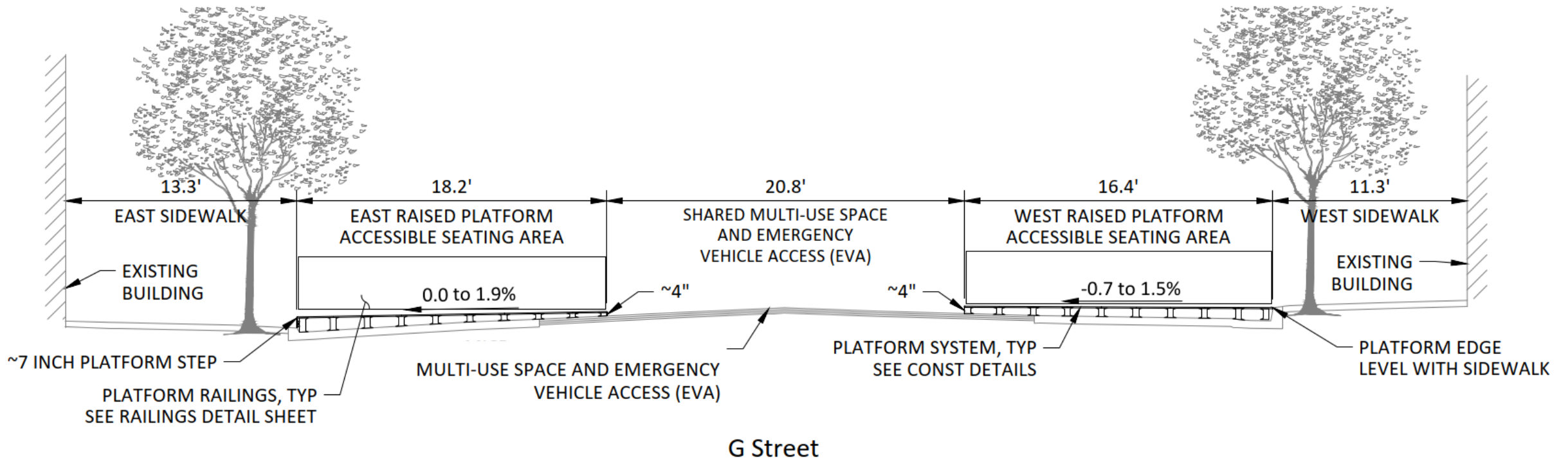

Platform



Barriers, Lighting and Banners

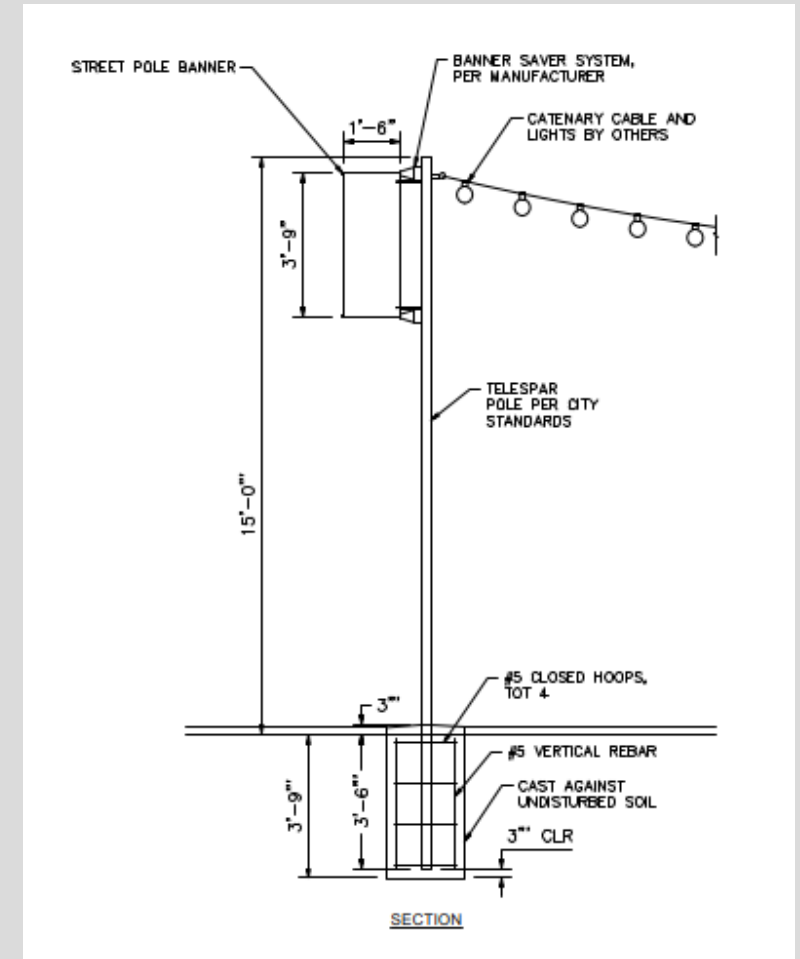
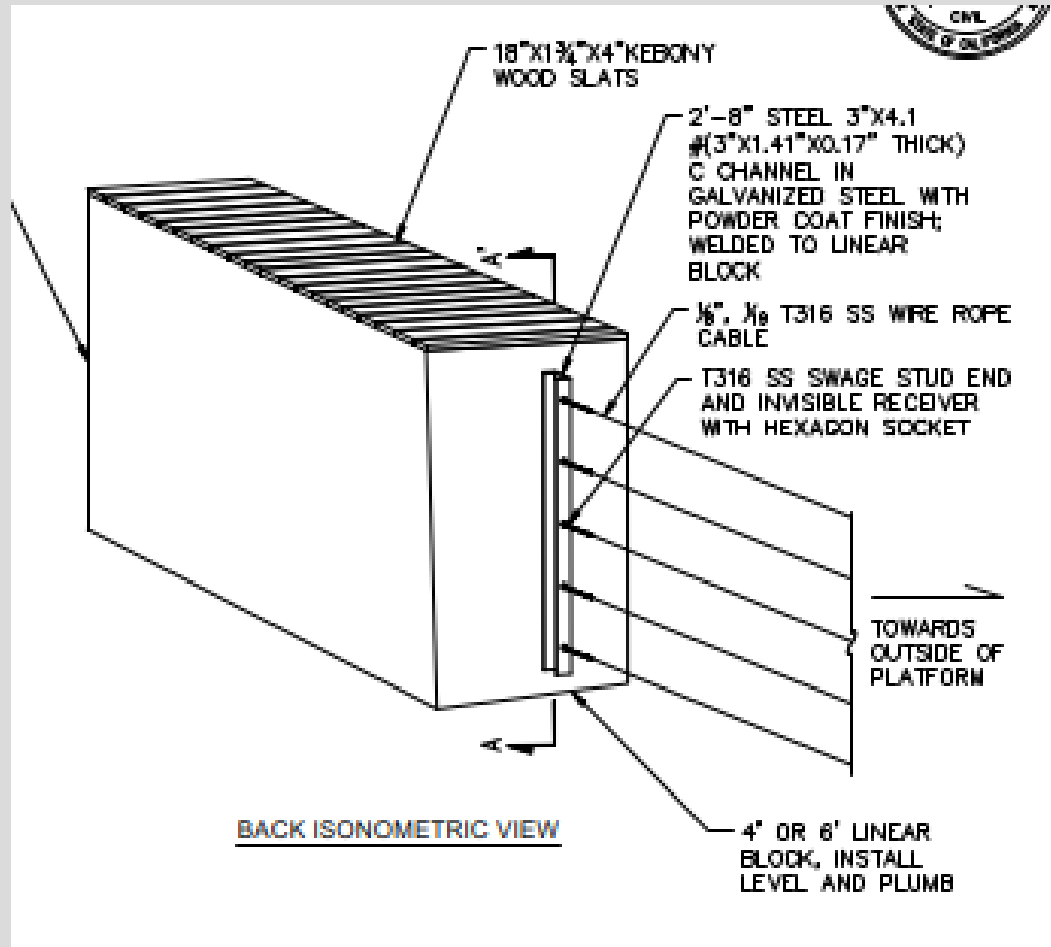

Seating Blocks

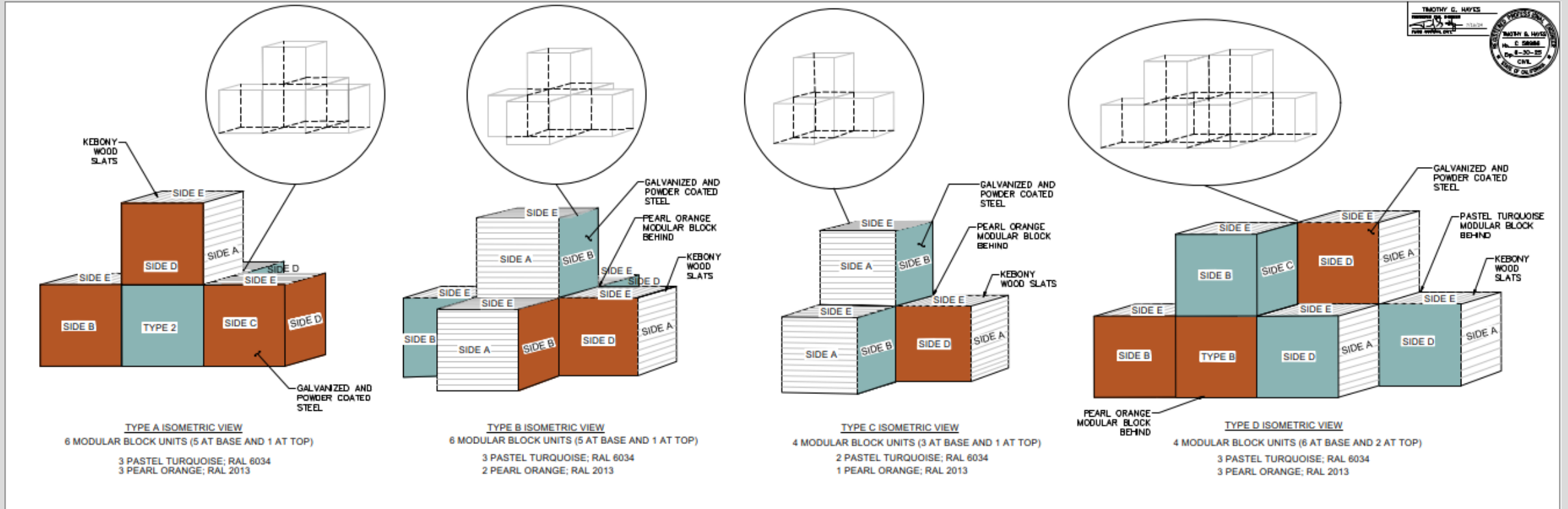

Tables



Tables



Schedule

- **Currently out to bid with an expected bid opening on Aug 9th.**
- **Contractor should be ready to start work later this month.**
- **Expect construction substantially complete mid November.**
- **All sidewalks will remain open and business entrances will be accessible.**

How to Provide Questions and Comments

- **Type your questions into the Q&A function**
- **Jennifer Donofrio will repeat out loud the questions that are relevant to this meeting/topic**
- **After meeting feel free to email us or me (RChapman@cityofdavis.org)**